

BROS

Train Axle Counter

- Control of up to 8 railway sections
- Up to 12 sensor pairs can be connected directly to the BROS
- Adjustable power supply AC/DC
- Reliable detection for train speed up to 350 km/h
- Device fulfills SIL 4 requirements according to CENELEC standards EN 50126, EN50128 and EN50129
- Data communication is in accordance with EN 50159
- Device is in accordance with the European directives



Axle Counter BROS is used to control occupancy of the railway sections. The device is placed into a standard 19-inch 3U height rack and it is mounted inside the relay room of the railway station, automatic block system, or level crossing.

Axle Counter BROS uses sensor pairs (SP) at the end of each section and it counts in axles that have entered the section, and counts out axles that have left the section. Sensor pair consists of two sensors (wheel detectors) which are placed opposite to each other on the rails.

In addition to the basic function of detecting the presence or the arrival of the train wheel, sensor pair also provides detection of the direction and speed of rail vehicles.

Key features

Providing outputs for 8 sections and having up to 12 directly connected sensor pairs, BROS device is perfectly suitable for usage within station interlocking system, as a relatively small number of devices can control all sections of the small, medium or large railway stations.

In the case using BROS for controlling occupancy within automatic signaling block (ABS), only two wires are enough for communication with adjacent axle counters.

BROS has two modems, which enable communication with maximum two neighboring axle counters, which is important for usage within ABS.

BROS supports all section topologies. Configuration stored in non-volatile memory provides all possible combinations between sensor pairs and relay outputs.

Additionally, there is ability to provide information about train direction separately via opto-coupler outputs.

Technical characteristics

- Dimensions:
 - 19" standard board rack
 - 3 U height
 - 84 pitch units width
- BROS device uses external power supply:
 - 11 – 28 VDC,
 - 48 – 72 VDC,
 - 220VAC
 - or any other AC/DC on demand
- Maximum power consumption is 60W.
- Operating temperature range is - 40 °C to + 70 °C.
- Reliable detection for train speed up to 350 km/h.
- Maximum number of axles per section is 9999.
- Possibility of the accommodation on the standard relay frame of the system SpDrS-64.
- One BROS device controls up to 8 railway sections.
- Each section can be configured as normal, automatic signaling block or train announcing section.
- Up to 12 sensor pairs (detection points) can be connected directly to one BROS device. Four wires are required for connection of detection point to BROS device.
- BROS device can communicate with up to two remote axle counters using modem communication. Two wires are required for modem communication between two BROS devices.
- Maximum distance between BROS device and detection point is 5 km using 0.9mm diameter wire when detection point is supplied from BROS device directly.
- Maximum communication distance is up to 20 km using 1.4mm diameter wire (On request, it is possible to deliver a solution with greater maximum distance).

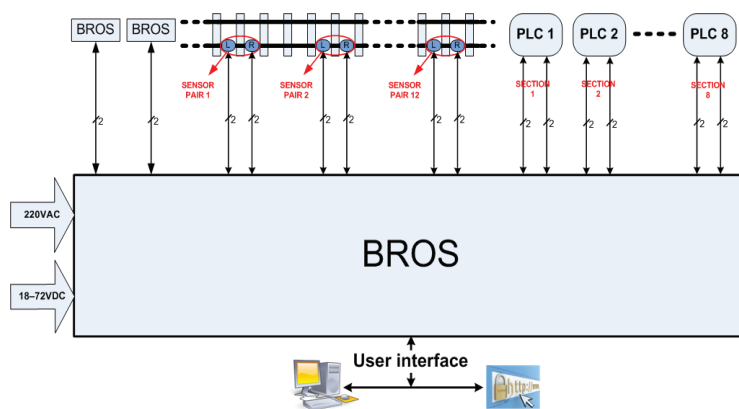

Additional features

- Possibility of importing and exporting sensor signals from nearby BROS devices enables continuous control of theoretically unlimited number of railway sections and detection points.
- Relay outputs for each section consist of two normally opened (N.O.) and two normally closed (N.C.) relay contacts. At least one N.O and one N.C. shall be used for safe operation. Double number of contacts for various applications (like relay automatic block section implementation) can be reached by using two output boards per section. In that case device has four normally opened (N.O.) and four normally closed (N.C.) relay contacts for one section.
- Every section can be reset locally using buttons of the front panel of the device, or remotely using opto-coupler inputs of the device. Section reset type can be either unconditional (immediate) or conditional (preparatory) reset. Section reset type can be configured separately for each section.
- BROS device stores all section reset events and changes of each section state in non-volatile memory.
- Possibility of remote section reset using modem communication (in case of automatic signaling block section).
- BROS device can provide remote supervision of current device state.

www.pupin.rs